

| DATE      | SYM | REVISION RECORD                   | BY: | DCN  |
|-----------|-----|-----------------------------------|-----|------|
| JUN 15 18 | A   | RELEASE TO PRODUCTION             | SCS | E505 |
| JUL 23 18 | B   | UPDATE LOGO                       | SCS | E532 |
| AUG 31 18 | C   | UPDATE ACCESS COVER               | SCS | E555 |
| SEP 17 18 | D   | ADD CAPTIVE WASHER                | SCS | E587 |
| JAN 3 19  | E   | ADD NOTE FOR ACCESS COVER CLARITY | SCS | E702 |

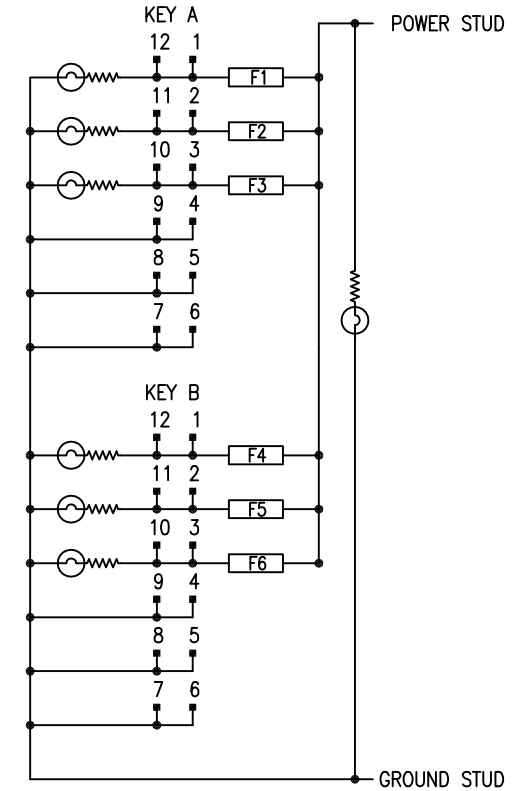

FUSE COVER IS SHOWN AS CLEAR FOR ILLUSTRATION PURPOSES ONLY, ACTUAL COVER IS BLACK.

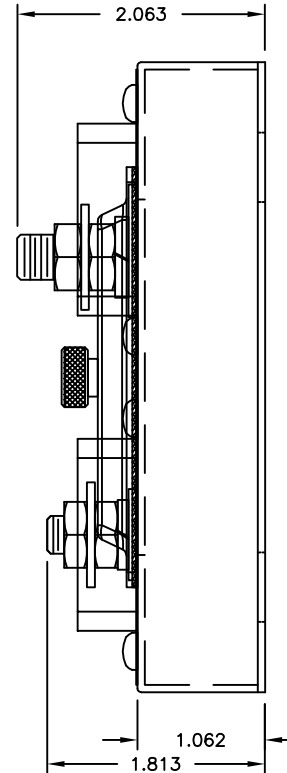
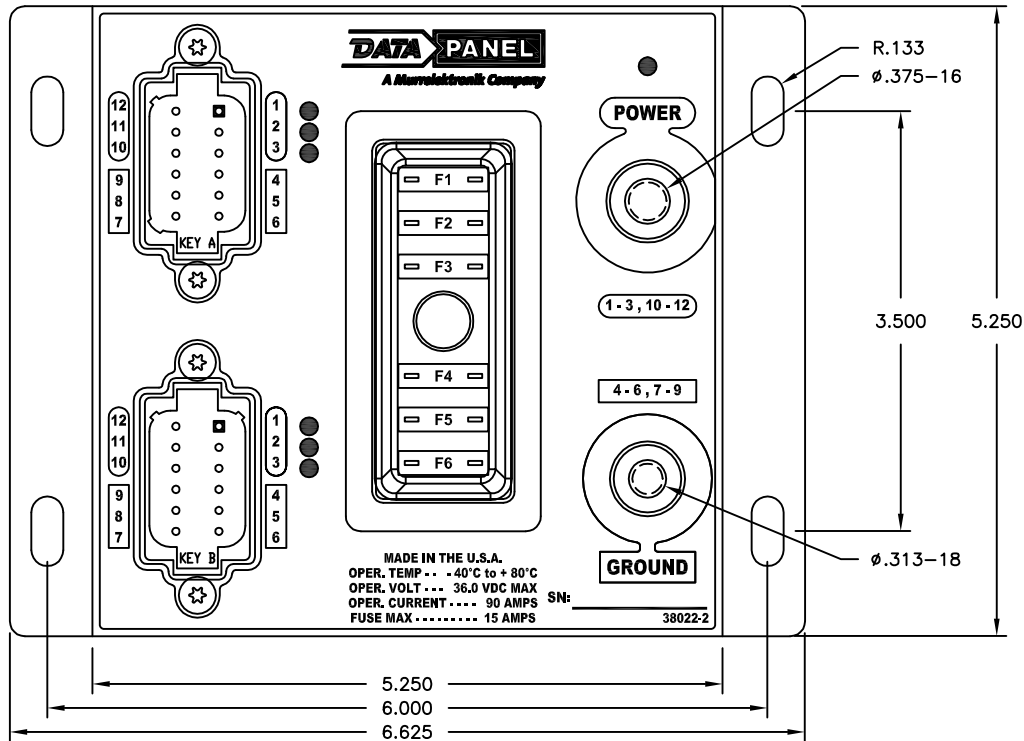
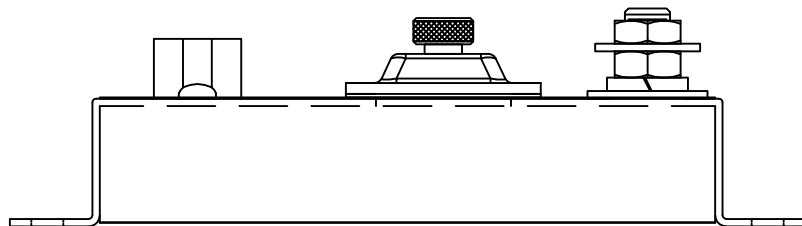

**NOTE:**

1. SEE 38022-102 FOR ASSEMBLY INSTRUCTIONS.
2. GRAPHIC BACKGROUND IS BLACK 121-001.
3. DATA PANEL LOGO IS WHITE.
4. OVALS ARE RED 121-049 WITH BLACK TEXT.
5. RECTANGLES ARE GRAY 121-091 WITH BLACK TEXT.
6. ALL OTHER TEXT IS WHITE 121-002.
7. DEUTSCH CONNECTOR: DT15-12PA AND DT15-12PB.
8. FUSE COVER IS BLACK ABS.
9. CASE IS ALUMINUM, ANODIZED BLACK.
10. COVER THUMB SCREW IS 8-32.
11. MOUNTING HOLES FOR .25" SCREWS (4X).
12. 15 AMP FUSE MAX. FUSES ARE NOT INCLUDED.

|   |   |                      |                         |              |                                    |  |
|---|---|----------------------|-------------------------|--------------|------------------------------------|--|
| DATA PANEL CORPORATION CLAIMS ALL PROPRIETARY RIGHTS TO THIS DRAWING AND THE INFORMATION IT CONTAINS. THIS DRAWING IS THE PROPERTY OF DATA PANEL CORPORATION AND IS NOT TO BE REPRODUCED OR TRANSMITTED IN ANY FORM OR BY ANY MEANS, ELECTRONIC OR MECHANICAL, INCLUDING PHOTOCOPYING, RECORDING, OR BY ANY INFORMATION STORAGE AND RETRIEVAL SYSTEM, WITHOUT THE EXPRESS WRITTEN PERMISSION OF DATA PANEL CORPORATION. DESIGN OR INVENTION ARE RESERVED. | <b>TOLERANCES</b><br>EXCEPT WHERE NOTED |                      | <b>DATA PANEL CORP.</b> |              |                                    |  |
|   | DECIMAL<br>± .010<br>± .03              | FRACTIONAL<br>± 1/32 | ANGULAR<br>± 1°         | CUSTOMER: X  |                                    |  |
|   | MATL: SEE NOTE                          |                      | SIZE<br>A               | SCALE<br>NTS | DRAWN BY<br>SCS                    |  |
|   | FINISH: SEE NOTE                        |                      | APP. BY                 |              | TITLE<br>PWR SPLITTER, FUSED, LEDs |  |
| DATE<br>APR 18 18   | DRAWING NUMBER<br>38022-2               |                      | REV.<br>E               |              |                                    |  |

